



System 8500 MPS 853

The System 8500 power supply program offers the 19 inch rack mount Magnet Power Supply 853.

The Magnet Power Supply 853 is a current regulated DC power supply with output currents up to 2000 A.

Stabilities in 10 or 1 ppm classes are offered as standard.

The power circuitry is of a conservative design with water cooled rectifier and transistor series regulator. The electronics design concept is assembled of System 8500 standardized modules, making service easy and fast.

An optional operator control panel is built into the power supply as standard and can be removed more than 100 m for remote control.

The Magnet Power Supply 853 offers you advanced power circuit technology, using the latest components combined with the normal high quality standards expected with a Danfysik power supply.

The power supply features

- Power range from 5-300 kW
- Current range from 120 to 2000 A
- 1 or 10 ppm stability class
- Incorporates Ultrastab Current Transducer
- Modular concept for easy servicing
- Water cooled power components
- Optional remote controllable via operator control panel
- RS232C interface port standard - IEEE-488 optional
- Custom built interfaces available

Applications

- Quadrupole magnets
- Small dipole magnets
- Ultra high stable laboratory magnets

Options

- Polarity reversal switch
- Optional water flow and earth leakage
- Rack with telescope rails, power and water distribution

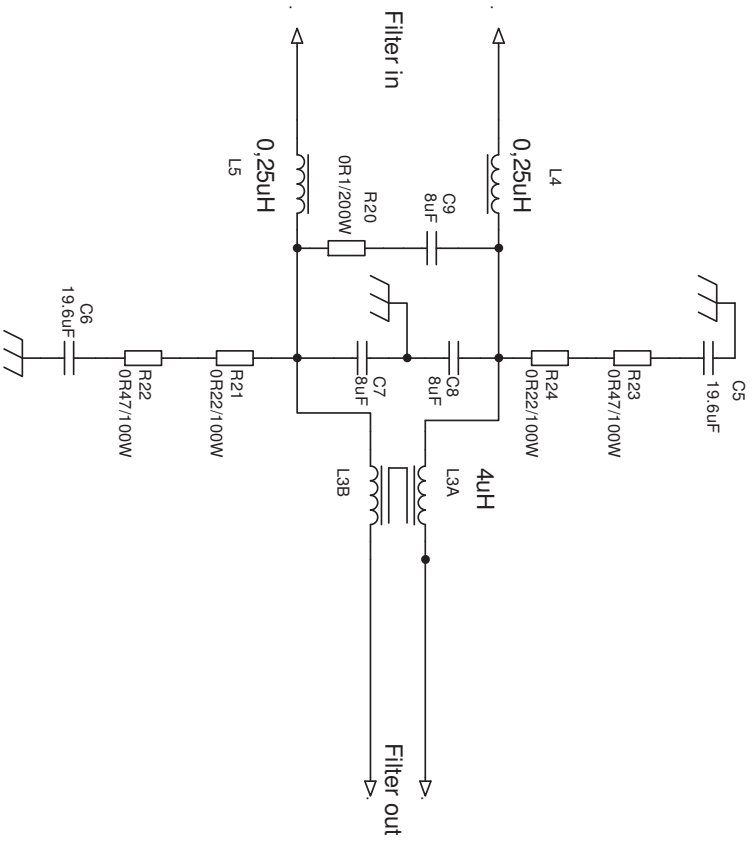

C5+C6 = 19.3uF , DF no: 12068519
 C7-9 = 8uF , DF no: 12068582
 Ferrit core, 12 ps. total, DF no. 13357630
 L3 = 4 uH, (gab = 0,25mm capton)
 L4 + L5 = 0.25 uH. (gab = 5mm capton)
 R20 = 0R1/200W, DF no. 11321010
 R21+R24 = 0R22/100W, DF no. 11302122
 R22+R23 = 0R47/100W, DF no. 11302147

MAGNET POWER SUPPLY
RF-filter 5-16 MHz
Schematic
MPS 853 / System 8000



CUSTOM. VECC	ORDER NO. 14201-201	REV. 1.0	SHEET. 1	OF 1
FILE: L:\CAD\85000\85236 RF FILTER 6-16MHZ FOR VECC\RF FILTER SCHEMATIC.DWG	PROJ. ENGR. HM	DRAWN BY. HM / 20.02.2004		
	PROJ. ENGR. HM	DESIGN APP.		
	DWG. NO.:	PROD APP.		
		85236		

Specifications

DC Output ratings

Power range	: 5 - 300 kW
Standard current range	: 120 - 2000 A
Voltage range	: 10 - 300 V

Performance

All drift and regulation data are given for max. current output.

Warm up time (cold start)	: 30 min.
Warm up time (from stand by)	: 15 min.

Drift

Short term 30 min. (fwhm)	: < +/- 3 ppm, optional < +/- 1 ppm
Long term 8 hours (fwhm)	: < +/- 10 ppm, optional < +/- 3 ppm

Line regulation

+/- 10% slow, T > 1 min.	: < 0.5 ppm
+/- 1% fast, T > 3 m sec.	: < 0.5 ppm

Load regulation

+/- 10% resistance change	: < 0.5 ppm
---------------------------	-------------

PARV (Periodic and Random Variations)

Output voltage f > 1 Hz (resistive load)	: 5 mV + 0.01% of V_{out}
--	-----------------------------

Temperature coefficient

Ambient	: 1 ppm/°C
---------	------------

DC output isolation resistance

: > 1 Mohm

Output polarity

: Remote controllable (optional)

Current setting resolution

Standard	: 16 bit (15 ppm)
Optional	: 18 bit (4 ppm)
Current fine control	: Up to +/- 1500 ppm for +/- 0.6 mA

Absolute calibration of current

: < 400 ppm

Current readback resolution

Standard	: 8 bit (3906 ppm)
Optional	: 16 bit (15 ppm)

Input/Output Interfaces

Operator Control Panel, Type M

Current setting by knob control with a digital bit generator. Three resolution ranges for the control of 1/10, 1/1000, and 1/100,000 per rev. of full scale.

Alphanumeric LCD display - with push-button selection of:

- Preset output current (%)
- Actual output current (%) - A (optional)
- Output output voltage (%) - V (optional)
- Transistor passbank voltage
- Interlock status text string

Regulation system status readback:

- Polarity (LED)
- Local remote (LED)

Computer Interface

- RS 232C/RS 422
- RS 422 Multidrop
- IEEE-488 (GPIB) (optional)
- Customer specified interface

Interlocks

- DC overcurrent and overload
- Regulation module failure
- Phase failure, thermal breaker
- Overtemperature
- Water flow and earth leakage (optional)
- Two user supplied inputs for remote shutdown

Temperature ratings

Operating	
Ambient	: 15 to 35°C
Water	: 15 to 35°C
Storage	: -20 to 50°C
Main cooling	: Water
Cooling water pressure:	
Minimum diff.	: 3 bar
Max. absolute	: 12 bar
Test pressure	: 15 bar

AC Input

Control Voltage,
single phase, 50-60 Hz, standard : Europe 220 V (+/- 5%) & USA 115 V (+/- 5%)
available on request : 110 V & 240 V

Mains voltage,
3 phase, 3 or 4 wire, 50-60 Hz, standard : Europe 380 V (+/- 5%) & USA 480 V (+/- 5%)
available on request : 208 V & 415 V & 565 V

Cabinet

Steel cabinet with aluminum front plate.

Operator Control Panel

Removable W x H x D : 19 inch rack mount x 88 x 75 mm